

**HILL COUNTY COVINGTON STREET ANNEX ROOF
REPAIRS AND REPLACEMENT
EXHIBIT "B"**

BIDDING INSTRUCTIONS

1. Existing roof construction description
 - Roof Area A is steel framed with bar joists and a bulb tee system.
 - Roof Area B is steel framed with bar joists and a metal roof deck.
2. Bid Alternates
 - Alternate One / Repair existing bulb tee system
 - Roof Area A:
 - A. Remove existing roofing membrane and insulation
 - B. Repair damaged areas of the bulb tee system (approximately 420 s.f.)
 - C. Install new roof insulation equal to Dupont Styrofoam Brand Deckmate XPS Insulation, 4" thick (R-20) required
 - D. Install new roofing system per specification.
 - Roof Area B:
 - A. Remove existing roofing membrane and insulation
 - B. Install new roof insulation equal to Dupont Styrofoam Brand Deckmate XPS Insulation, 4" thick (R-20) required
 - C. Install new roofing system per specification.
 - Alternate Two / Install new metal roof deck over existing bulb tee system
 - Roof Area A:
 - A. Remove existing roofing membrane, insulation and gypsum
 - B. Install new metal roof deck over existing framing (see structural general notes for instructions)
 - C. Install new roof insulation equal to Dupont Styrofoam Brand Deckmate XPS Foam Insulation, 4" thick (R-20) required
 - D. Install new roofing system per specification.
 - Roof Area B:
 - A. Remove existing roofing membrane and insulation
 - B. Install new roof insulation equal to Dupont Styrofoam Brand Deckmate XPS Foam Insulation, 4" thick (R-20) required
 - C. Install new roofing system per specification.
3. Proposers must bid both Alternates.

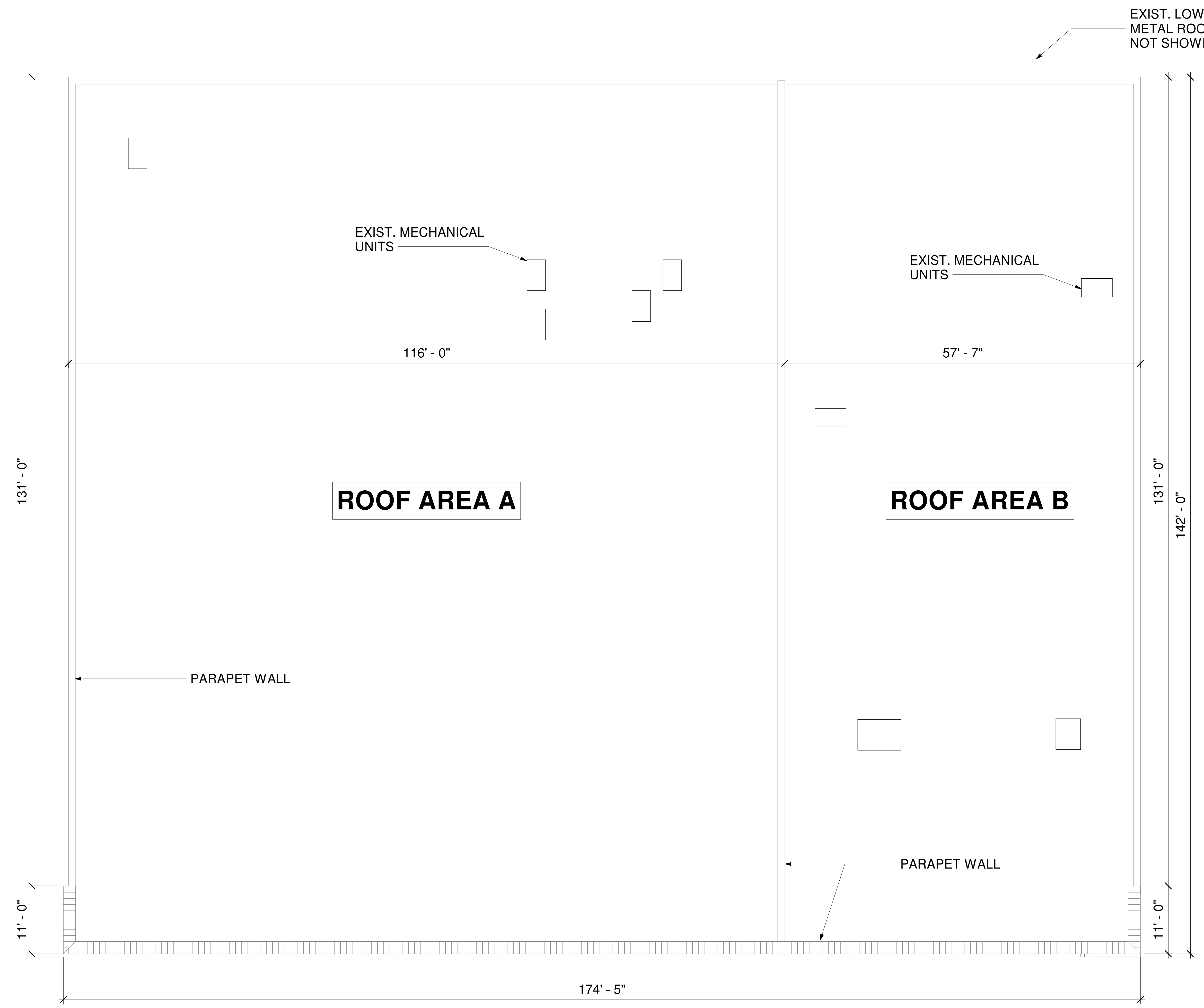

① ROOF PLAN
1/8" = 1'-0"



BURNS ARCHITECTURE, LLC
2802 FLINTTICK TRACE, SUITE B102
AUSTIN, TEXAS 78738
Copyright 2019;
KENNETH C. BURNS, AIA.

HILL COUNTY
COVINGTON STREET ANNEX ROOF
REPAIRS AND REPLACEMENT
126 COVINGTON STREET
HILLSBORO, TX

No.	Revision	Date

NOTE: DO NOT SCALE DRAWING
**CONSTRUCTION
DRAWINGS**

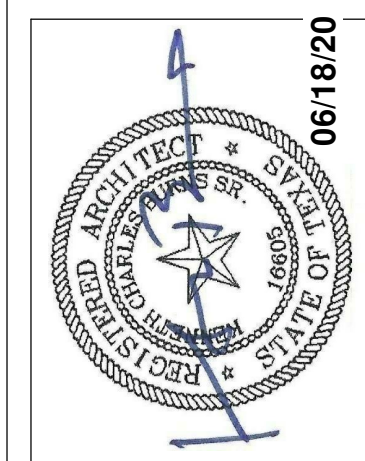

Project Number: HCCAF-19
Date: 06/18/20
Scale: 1/8" = 1'-0"
ROOF PLAN

A1.0

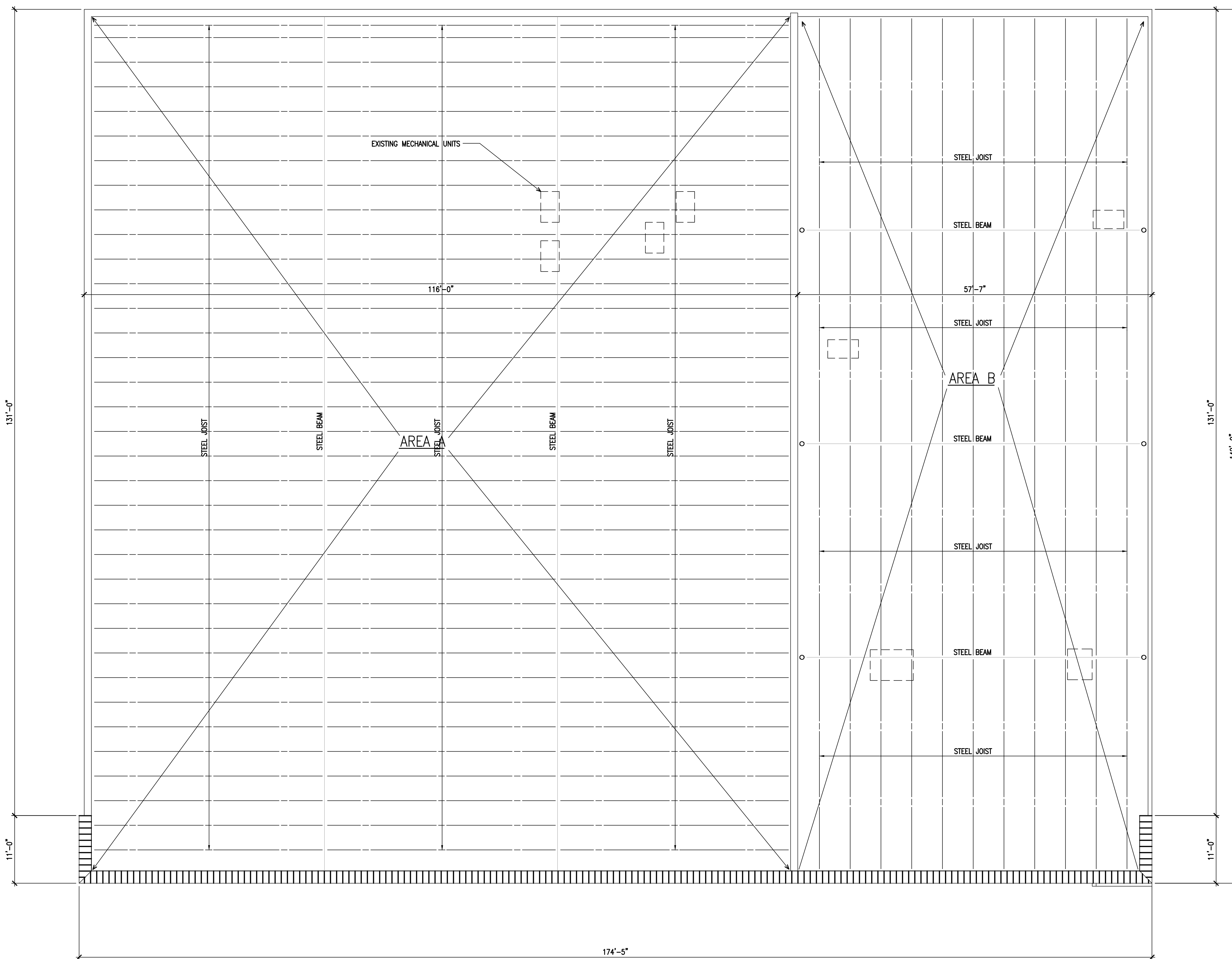

1 | FRAMING PLAN
 NORTH 1/8" = 1'-0"

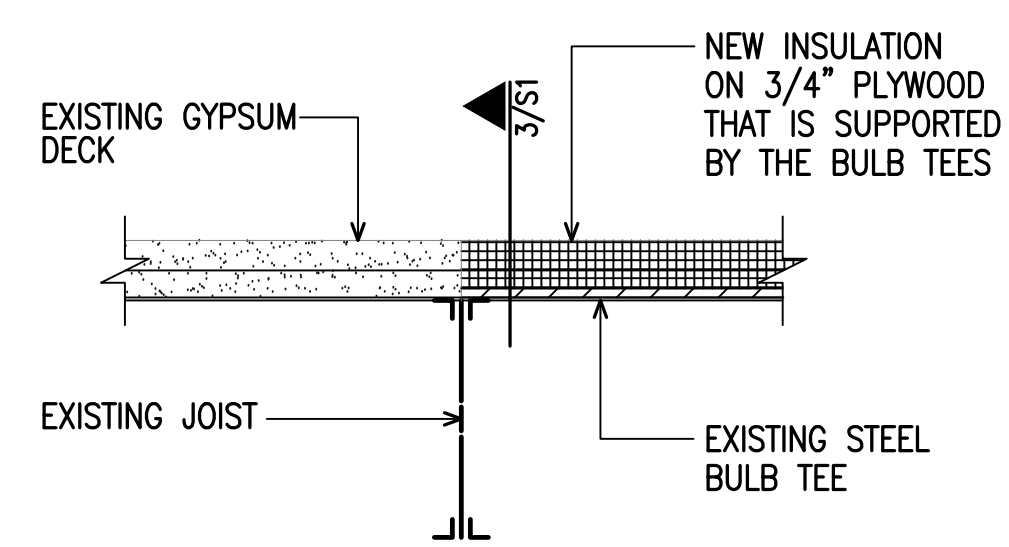

2 | DETAIL
 N.T.S.

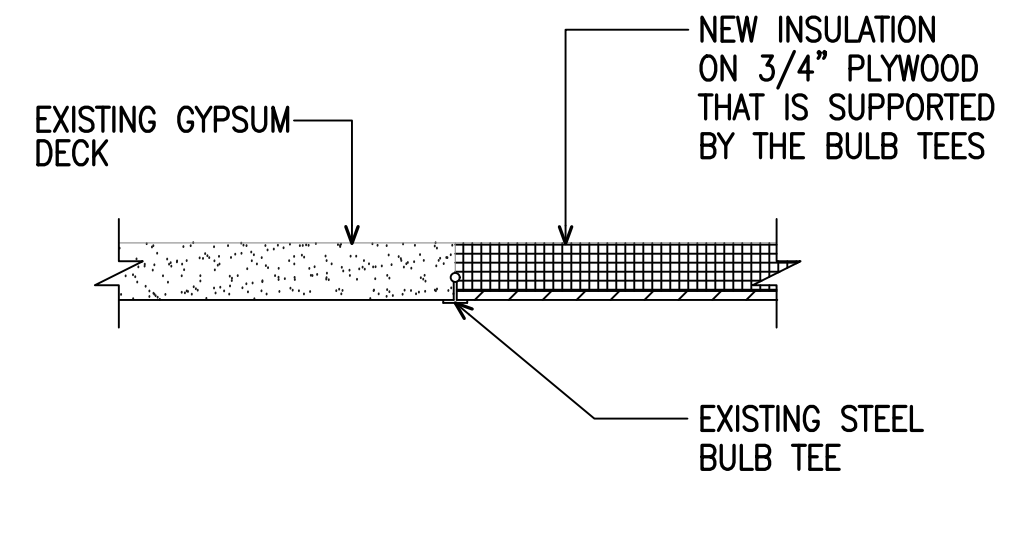

3 | DETAIL
 N.T.S.

- ROOF DESCRIPTION**
- AREA A**
1. THE ROOF STRUCTURE IS STEEL JOISTS ON STEEL BEAMS.
 2. STEEL BULB TEES SUPPORT GYPSUM DECK
 3. THE STEEL JOISTS ARE SPACED AT 4 FEET ON CENTER EXCEPT ALONG THE WEST WALL WHERE THEY ARE SPACED AT 2 FEET ON CENTER
 4. THE AREA OF GYPSUM DECK TO BE REPLACED SHALL USE THE REPLACEMENT DETAIL PER THESE DOCUMENTS
 5. THE APPROXIMATE AREA TO BE REPLACED IS 420 SQUARE FEET. REFER TO BID DOCUMENTS FOR SQUARE FOOTAGE COST.
 6. REFER TO GENERAL NOTES FOR METAL DECK REPLACEMENT.
- AREA B**
1. THE ROOF STRUCTURE IS STEEL JOISTS ON STEEL BEAMS.
 2. 1 1/2" ROOF DECK IS ATTACHED TO THE STEEL JOISTS.
 3. THE STEEL JOISTS ARE SPACED AT APPROXIMATELY 5 FEET ON CENTER

GENERAL NOTES

I. GENERAL CONDITIONS & DESIGN LOADS

1. Building Code: 2018 International Building Code
2. Risk Category II
3. Roof Dead Loads

Roofing	2.5 psf
Decking	1.8 psf
Joists or Rafter or Trusses	2.0 psf
Ceiling	2.0 psf
Insulation	2.5 psf
Mechanical and Electrical	2.0 psf
Miscellaneous	1.0 psf

4. Live Loads

OCCUPANCY OR USE	UNIFORM (psf)	CONCENTRATED (pounds)
Roofs		300
All roof surfaces subject to maintenance workers		
Ordinary flat, pitched, and curved roofs (that are not occupiable)	20	

5. Roof Snow Load Data

Ground snow load, P _g	5 psf
Flat-roof snow load, P _f	3.8 psf
Snow exposure factor, C _e	1.0
Snow load importance factor, I _s	1.0
Thermal factor, C _t	1.0
Slope factor, C _s	1.0

6. Wind Design Data

Ultimate design wind speed, V _{ult}	115 mph
Nominal design wind speed, V _{nom}	89 mph
Wind Importance Factor, I _w	1.0
Wind exposure	B
Internal pressure coefficient	+/-0.18

7. Earthquake Design Data

Seismic importance factor, I _e	1.0
Mapped spectral response acceleration (short period), S _s	0.08 g
Mapped spectral response acceleration (1 sec. period), S ₁	0.05 g
Site class	D
Design spectral response acceleration (short period), S _{DS}	0.10 g
Design spectral response acceleration (1 sec. period), S _{1D}	0.07 g
Seismic design category	B
Basic seismic force-resisting system(s)	Shear walls
Response modification coefficient(s), R	5
Analysis procedure used:	Equivalent Lateral Force Analysis
Seismic response coefficient(s), C _s	0.014
Design base shear(s), V	4 kips

8. General
 - a. Contractor shall verify all dimensions prior to start of construction.
 - b. General Contractor shall be responsible for coordination of architectural and structural drawings prior to fabrication, forming, or placement of materials. General Contractor shall report discrepancies immediately to Architect and shall proceed with construction only after discrepancy has been resolved.
 - c. The details designated as "Typical Details" (TYP) apply generally to the drawings in all areas where conditions are similar.
 - d. Contractor shall review architectural sheets for miscellaneous steel.
 - e. Hangers supporting piping, ceilings, light fixtures, and suspended framing shall not be attached to roof deck. Hangers shall be connected to roof joist, beams, or headers provided to span between roof framing members. [Hanger spacing shall not exceed 2 times the spacing of the roof framing members. Hanger load shall not exceed a uniform load of (10/15/20) psf.]

II. ROOF DECK

1. Metal deck schedule:

Deck Gauge	Deck Type	Deck Depth	Sheet Width	S ₁ (in/ft)	S ₂ (in/ft)	I ₁ (in/ft)	I ₂ (in/ft)	Finish
22	WR	1.5"	36"	0.186	0.192	0.155	0.183	Painted

2. Roof deck shall be continuous over three (3) spans minimum.
3. Suspended ceilings, light fixtures, ducts or other utilities shall not be supported by the steel deck.
4. Metal deck connection schedule:

Location	Connection at Supports	Connection at Parallel Edges	Sidelap Connection No./Span	Required Shear Capacity (k)
I	3/8"	12" o.c.	2	244

5. Support and parallel edge connections shall be:
 - a. Hilti X-HSN 24 for steel joist of chord thickness between 1/8" and 3/8"
 - b. Hilti X-ENP 19 for steel beam of flange thickness greater than 1/4"
6. Sidelap connections shall be Hilti SLC-01.
7. Provide 18" wide 20 gage filler sheets centered on non-nesting side laps as required. Connect as per note 4 above.

III. SHOP DRAWINGS AND SUBMITTALS

1. Shop drawings shall be prepared and submitted for review to the Architect/Engineer for each structural building material as specified in the structural General Notes and the Project Specifications. See the contract specifications for submittal procedures and additional information.
2. Shop drawings shall use drafting line work and lettering that is clearly legible. Shop drawings shall not contain reproductions of the contract drawing plans or details. Shop drawings shall not show materials for more than one level on the same plan.
3. Shop drawings shall show clear and complete information for the fabrication and installation of materials. Erection and placing drawing shall provide every note and detail required to correctly install materials; they shall not refer to the contract documents for installation information.
4. Erection and placing drawing plans shall be oriented and referenced in the same manner as plans on the contract documents.
5. Shop drawings shall list the grade, class and/or strength of materials.
6. Submittals received by the Architect/Engineer which are insufficient or incomplete may be rejected and returned to the Contractor without review. The Contractor shall be responsible for any delays in the construction schedule due to rejected, insufficient, or incomplete shop drawing submittals.
7. Shop drawings shall be checked and initialed by the supplier prior to submittal to the Contractor.
8. The Contractor shall thoroughly check, coordinate, stamp, date and initial each and every shop drawing print prior to submittal to the Architect/Engineer for review. Shop drawings, which do not meet these requirements, shall be considered incomplete and returned to the Contractor without review.
9. Contractor's request to deviate from the contract documents shall be clearly identified by "clouding" on the shop drawings.
10. Resubmitted shop drawings shall clearly identify items that have been corrected. Shop Drawings that are resubmitted with revisions that are not clouded shall be rejected and returned to the Contractor without review.

IV. SPECIAL INSPECTIONS

1. The Owner shall employ one or more Special Inspectors to perform this work. The Special Inspector(s) shall keep records of all inspections and furnish interim inspection reports to the Building Official and to the Registered Design Professional in Responsible Charge. Discrepancies shall be brought to the immediate attention of the Contractor for correction. If the discrepancies are not corrected, the discrepancies shall be brought to the attention of the Building Official and the Registered Design Professional in Responsible Charge prior to completion of that phase of work. A Final Report of Special Inspections documenting required Special Inspection and correction of any discrepancies noted in the inspections shall be submitted to the Building Official and the Registered Design Professional in Responsible Charge at the conclusion of the project.
2. The Special Inspection program does not relieve the Contractor of responsibility to comply with the Contract Documents.



SECTION 075419
POLYVINYL-CHLORIDE ROOFING

PART 1 GENERAL

1.1 SECTION INCLUDES

- A. Overlay BUR: Granular-Surfaced Cap Sheet.
- B. Duro-Last® Duro-Fleece™ membrane adhered with Duro-Fleece CR-20 membrane adhesive, splatter applied.
- C. Prefabricated flashings, corners, parapets, stacks, vents, and related details.
- D. Fasteners, adhesives, and other accessories required for a complete roofing installation.
- E. Traffic Protection.

1.2 REFERENCES

- A. NRCA - The NRCA Roofing and Waterproofing Manual.
- B. ASCE 7 - Minimum Design Loads For Buildings And Other Structures.
- C. UL - Roofing Materials and Systems Directory, Roofing Systems (TGFU.R10128).
- D. ASTM C 1289 - Standard Specification for Faced Rigid Cellular Polyisocyanurate Thermal Insulation Board.
- E. ASTM D 751 - Standard Test Methods for Coated Fabrics.
- F. ASTM D 4434 - Standard Specification for Poly(Vinyl Chloride) Sheet Roofing.
- G. ASTM E 108 - Standard Test Methods for Fire Tests of Roof Coverings.
- H. ASTM E 119 - Standard Test Methods for Fire Tests of Building Construction and Materials.

1.3 SYSTEM DESCRIPTION

- A. General: Provide installed roofing membrane and base flashings that remain watertight; do not permit the passage of water; and resist specified uplift pressures, thermally induced movement, and exposure to weather without failure.
- B. Material Compatibility: Provide roofing materials that are compatible with one another under conditions of service and application required, as demonstrated by roofing membrane manufacturer based on testing and field experience.
- C. Physical Properties:
 - 1. Roof product must meet the requirements of Type III PVC sheet roofing as defined by ASTM D 4434 and must meet or exceed the following physical properties.
 - 2. Thickness: 50 mil (68 mil including fleece), nominal, in accordance with ASTM D 751.
 - 3. Thickness Over Scrim: ≥ 28 mil in accordance with ASTM D 751.
 - 4. Breaking Strengths: ≥ 500 lbf. (MD) and ≥ 344 lbf. (XMD) in accordance with ASTM D 751, Grab Method.

5. Elongation at Break: $\geq 32\%$ (MD) and $\geq 77\%$ (XMD) in accordance with ASTM D 751, Grab Method.
 6. Heat Aging in accordance with ASTM D 3045: 176 °F for 56 days. No sign of cracking, chipping or crazing. (In accordance with ASTM D 4434).
 7. Factory Seam Strength: ≥ 278 lbf. in accordance with ASTM D 751, Grab Method.
 8. Tearing Strength: ≥ 67 lbf. (MD) and ≥ 160 lbf. (XMD) in accordance with ASTM D 751, Procedure B.
 9. Low Temperature Bend (Flexibility): Pass at -40 °F in accordance with ASTM D 2136.
 10. Accelerated Weathering: No cracking, checking, crazing, erosion or chalking after 5,000 hours in accordance with ASTM G 154.
 11. Linear Dimensional Change: $\leq 0.11\%$ (MD) and 0.11% (XMD) in accordance with ASTM D 1204 at 176 ± 2 °F for 6 hours.
 12. Water Absorption: $\leq 2.7\%$ in accordance with ASTM D 570 at 158 °F for 166 hours.
 13. Static Puncture Resistance: ≥ 33 lbs. in accordance with ASTM D 5602.
 14. Dynamic Puncture Resistance: ≥ 14.7 ft-lbf. in accordance with ASTM D 5635.
- D. Cool Roof Rating Council (CRRC):
1. Membrane must be listed on CRRC website.
 - a. Initial Solar Reflectance: $\geq 87\%$
 - b. Initial Solar Reflective Index (SRI): ≥ 110

1.4 SUBMITTALS

- A. Submit shop drawing and product information to Architect prior to commencement of work.
- B. Duro-Last data sheets on each product to be used, including:
 1. Preparation instructions and recommendations.
 2. Storage and handling requirements and recommendations.
 3. Installation methods.
 4. Maintenance requirements.
- C. Shop Drawings: Indicate insulation pattern, overall membrane layout, field seam locations, joint or termination detail conditions, and location of fasteners.
- D. Verification Samples: For each product specified, two samples, representing actual product, color, and finish.
 1. 4 inch by 6 inch sample of roofing membrane, of color specified.
 2. 4 inch by 6 inch sample of walkway pad.
3. Termination bar, fascia bar with cover, drip edge and gravel stop if to be used.
4. Each fastener type to be used for installing membrane, insulation/recover board, termination bar and edge details.

- E. Installer Certification: Certification from the roofing system manufacturer that Installer is approved, authorized, or licensed by manufacturer to install roofing system.
- F. Manufacturer's warranties.

1.5 QUALITY ASSURANCE

- A. Perform work in accordance with manufacturer's installation instructions.
- B. Manufacturer Qualifications: A manufacturer specializing in the production of PVC membranes systems and utilizing a Quality Control Manual during the production of the membrane roofing system that has been approved by and is inspected by Underwriters Laboratories.
- C. Installer Qualifications: Company specializing in installation of roofing systems similar to those specified in this project and approved by the roofing system manufacturer.
- D. Source Limitations: Obtain components for membrane roofing system from roofing membrane manufacturer.
- E. There shall be no deviations from the roof membrane manufacturer's specifications or the approved shop drawings without the prior written approval of the manufacturer.

1.6 REGULATORY REQUIREMENTS

- A. Conform to applicable code for roof assembly wind uplift and fire hazard requirements.
- B. Fire Exposure: Provide membrane roofing materials with the following fire-test-response characteristics. Materials shall be identified with appropriate markings of applicable testing and inspecting agency.
 - 1. Exterior Fire-Test Exposure:
 - a. Class A; ASTM E 108, for application and roof slopes indicated.
 - 2. Fire-Resistance Ratings: Comply with ASTM E 119 for fire-resistance-rated roof assemblies of which roofing system is a part.
 - 3. Conform to applicable code for roof assembly fire hazard requirements.
- C. Wind Uplift:
 - 1. Roofing System Design: Provide a roofing system designed to resist uplift pressures calculated according to the current edition of the ASCE-7 Specification *Minimum Design Loads for Buildings And Other Structures*.

1.7 PRE-INSTALLATION MEETING

- A. Convene meeting not less than one week before starting work of this section.
- B. Review methods and procedures related to roof deck construction and roofing system including, but not limited to, the following.
 - 1. Meet with Owner, Architect, Owner's insurer if applicable, testing and inspecting agency representative, roofing installer, roofing system manufacturer's representative, deck installer, and installers whose work interfaces with or affects roofing including installers of roof accessories and roof-mounted equipment.

2. Review and finalize construction schedule and verify availability of materials, installer's personnel, equipment, and facilities needed to make progress and avoid delays.
3. Examine deck substrate conditions and finishes for compliance with requirements, including flatness and fastening.
4. Review structural loading limitations of roof deck during and after roofing.
5. Review base flashings, special roofing details, roof drainage, roof penetrations, equipment curbs, and condition of other construction that will affect roofing system.
6. Review governing regulations and requirements for insurance and certificates if applicable.
7. Review temporary protection requirements for roofing system during and after installation.
8. Review roof observation and repair procedures after roofing installation.

1.8 DELIVERY, STORAGE AND HANDLING

- A. Deliver roofing materials to Project site in original containers with seals unbroken and labeled with manufacturer's name, product brand name and type, date of manufacture, and directions for storing and mixing with other components.
- B. Store liquid materials in their original undamaged containers in a clean, dry, protected location and within the temperature range required by roofing system manufacturer. Protect stored liquid material from direct sunlight.
- C. Protect roof insulation materials from physical damage and from deterioration by sunlight, moisture, soiling, and other sources. Store in a dry location. Comply with insulation manufacturer's written instructions for handling, storing, and protecting during installation.
- D. Store roof materials and place equipment in a manner to avoid permanent deflection of deck.
- E. Store and dispose of solvent-based materials, and materials used with solvent-based materials, in accordance with requirements of local authorities having jurisdiction.

1.9 WARRANTY

- A. Contractor's Warranty: The contractor shall warrant the roof application with respect to workmanship and proper application for two (2) years from the effective date of the warranty issued by the manufacturer.
- B. Manufacturer's Warranty: Must be no-dollar limit type and provide for completion of repairs, replacement of membrane or total replacement of the roofing system at the then-current material and labor prices throughout the life of the warranty. In addition the warranty must meet the following criteria:
 1. Warranty Period: 15 years from date issued by the manufacturer.
 2. No exclusion for damage caused by ponding water.
 3. Issued direct from and serviced by the roof membrane manufacturer.
 4. Transferable for the full term of the warranty.
 5. No additional charge for the warranty.

PART 2 PRODUCTS

2.1 MANUFACTURER

- A. Manufacturer: Duro-Last Roofing, Inc., which is located at: 525 Morley Drive, Saginaw, MI 48601. Telephone: 800-248-0280.
- B. All roofing system components to be provided or approved by Duro-Last Roofing, Inc.
- C. Substitutions: Product equal to this specification which is the basis-of-design.

2.2 ROOFING SYSTEM COMPONENTS

- A. Roofing Membrane: Duro-Last® Duro-Fleece™ membrane conforming to ASTM D 4434, type III, fabric-reinforced, PVC, NSF/ANSI 347 Gold or Platinum Certification, and a product-specific third-party verified Environmental Product Declaration. Membrane properties as follows:
 - 1. Thickness:
 - a. 50 mil nominal (68 mil including fleece).
 - 2. Exposed Face Color:
 - a. White.
 - 3. Minimum recycle content 7% post-industrial and 0% post-consumer.
 - 4. Recycled at end of life into resilient flooring or concrete expansion joints.
- B. Accessory Materials: Provide accessory materials supplied by or approved for use by Duro-Last Roofing, Inc.
 - 1. Sheet Flashing: Manufacturer's standard reinforced PVC sheet flashing.
 - 2. Duro-Last Factory Prefabricated Flashings: manufactured using Manufacturer's standard reinforced PVC membrane.
 - a. Stack Flashings.
 - b. Curb Flashings.
 - c. Inside and Outside Corners.
 - 3. Sealants and Adhesives: Compatible with roofing system and supplied by Duro-Last Roofing, Inc.
 - a. Duro-Fleece® CR-20 Membrane Adhesive.
 - b. Duro-Caulk® Plus.
 - c. Strip Mastic.
 - 4. Slip Sheet: Compatible with roofing system and supplied by Duro-Last Roofing, Inc.
 - 5. Fasteners and Plates: Factory-coated steel fasteners and metal or plastic plates meeting corrosion-resistance provisions in FMG 4470, designed for fastening membrane and insulation to substrate. Supplied by Duro-Last Roofing, Inc.
 - a. Concrete Screws.
 - 6. PV Anchors
 - 7. Termination and Edge Details: Supplied by Duro-Last Roofing, Inc.

- a. Termination Bar.
 - b. Kynar Steel Fascia Cover.
8. Vinyl Coated Metal: Supplied by Duro-Last Roofing, Inc. 24 gauge, hot-dipped galvanized, grade 90 metal with a minimum of 17 mil of Duro-Last membrane laminated to one side.
- C. Walkways:
- 1. Provide non-skid, maintenance-free walkway pads in areas of heavy foot traffic and around mechanical equipment.
 - a. Duro-Last Roof Trak® III Walkway Pad.
 - 1.

PART 3 EXECUTION

3.1 EXAMINATION

- A. Verify that the surfaces and site conditions are ready to receive work.
- B. Verify that the deck is supported and secured.
- C. Verify that the deck is clean and smooth, free of depressions, waves, or projections, and properly sloped to drains, valleys, eaves, scuppers or gutters.
- D. Verify that the deck surfaces are dry and free of standing water, ice or snow.
- E. Verify that all roof openings or penetrations through the roof are solidly set.
- F. If substrate preparation is the responsibility of another contractor, notify Architect of unsatisfactory preparation before proceeding.
- G. Prior to re-covering an existing roofing system, conduct an inspection of the roof system accompanied by a representative of the membrane manufacturer or an authorized contractor.
 - 1. Determine required fastener type, length, and spacing.
 - 2. Verify that moisture content of existing roofing is within acceptable limits.
 - 3. Identify damaged areas requiring repair before installation of new roofing.
 - 4. Conduct core cuts as required to verify information required.

3.2 PREPARATION

- A. Clean surfaces thoroughly prior to installation.
- B. Prepare surfaces using the methods recommended by the manufacturer for achieving the best result for the substrate under the project conditions.
- C. Surfaces shall be clean, smooth, free of fins, sharp edges, loose and foreign material, oil, grease, and bitumen.

3.3 INSTALLATION

- A. Install insulation in accordance with the roof manufacturer's requirements.

- B. Roof Membrane: 50 mil, Duro-Last® Duro-Fleece™ membrane.
1. Use only membrane adhesive acceptable to the roof manufacturer's that meets the applicable design requirements.
 2. Cut membrane to fit neatly around all penetrations and roof projections.
 3. Unroll roofing membrane and positioned with a minimum 6 inch overlap along the selvage edge. Roll ends must be butted together and membrane of the same mil thickness, without fleece backing, must be used to form the end lap.
 4. Apply adhesive in accordance with the roof manufacturer's requirements.
 5. Apply adhesive in splatter pattern.
 6. Follow guidelines outlined in the adhesive's Product Data Sheet.
 7. Read the adhesive's Material Safety Data Sheet (MSDS) prior to using the adhesive.
- C. Seaming:
1. Weld overlapping sheets together using hot air. Minimum weld width is 1-1/2 inches.
 2. Check field welded seams for continuity and integrity and repair all imperfections by the end of each work day.
- D. Membrane Termination/Securement: All membrane terminations shall be completed in accordance with the membrane manufacturer's requirements.
1. Provide securement at all membrane terminations at the perimeter of each roof level, roof section, curb flashing, skylight, expansion joint, interior wall, penthouse, and other similar condition.
 2. Provide securement at any angle change where the slope or combined slopes exceeds two inches in one horizontal foot.
- E. Flashings: Complete all flashings and terminations as indicated on the drawings and in accordance with the membrane manufacturer's requirements.
1. Provide securement at all membrane terminations at the perimeter of each roof level, roof section, curb flashing, skylight, expansion joint, interior wall, penthouse, and other similar condition.
 - a. Do not apply flashing over existing thru-wall flashings or weep holes.
 - b. Secure flashing on a vertical surface before the seam between the flashing and the main roof sheet is completed.
 - c. Extend flashing membrane a minimum of 6 inches (152 mm) onto the main roof sheet beyond the mechanical securement.
 - d. Use care to ensure that the flashing does not bridge locations where there is a change in direction (e.g. where the parapet meets the roof deck).
 2. Penetrations:
 - a. Flash all pipes, supports, soil stacks, cold vents, and other penetrations passing through the roofing membrane as indicated on the Drawings and in accordance with the membrane manufacturer's requirements.
 - b. Utilize custom prefabricated flashings supplied by the membrane manufacturer.
 - c. Existing Flashings: Remove when necessary to allow new flashing to terminate directly to the penetration.

3. Pipe Clusters and Unusual Shapes:
 - a. Clusters of pipes or other penetrations which cannot be sealed with prefabricated membrane flashings shall be sealed by surrounding them with a prefabricated vinyl-coated metal pitch pan and sealant supplied by the membrane manufacturer.
 - b. Vinyl-coated metal pitch pans shall be installed, flashed and filled with sealant in accordance with the membrane manufacturer's requirements.
 - c. Pitch pans shall not be used where prefabricated or field fabricated flashings are possible.

F. Roof Drains:

1. Coordinate installation of roof drains and vents specified in Section 15146 - Plumbing Specialties.
2. Remove existing flashing and asphalt at existing drains in preparation for sealant and membrane.
3. Provide a smooth clean surface on the mating surface between the clamping ring and the drain base.

G. Edge Details:

1. Provide edge details as indicated on the Drawings. Install in accordance with the membrane manufacturer's requirements.
2. Join individual sections in accordance with the membrane manufacturer's requirements.
3. Coordinate installation of metal flashing and counter flashing specified in Section 07620.
4. Manufactured Roof Specialties: Coordinate installation of copings, counter flashing systems, gutters, downspouts, and roof expansion assemblies specified in Section 07710.

H. Walkways:

1. Install walkways in accordance with the membrane manufacturer's requirements.
2. Provide walkways where indicated on the Drawings.
3. Install walkway pads at roof hatches, access doors, rooftop ladders and all other traffic concentration points regardless of traffic frequency. Provided in areas receiving regular traffic to service rooftop units or where a passageway over the surface is required.
4. Do not install walkways over flashings or field seams until manufacturer's warranty inspection has been completed.

I. Water cut-offs:

1. Provide water cut-offs on a daily basis at the completion of work and at the onset of inclement weather.
2. Provide water cut-offs to ensure that water does not flow beneath the completed sections of the new roofing system.
3. Remove water cut-offs prior to the resumption of work.
4. The integrity of the water cut-off is the sole responsibility of the roofing contractor.
5. Any membrane contaminated by the cut-off material shall be cleaned or removed.

3.4 FIELD QUALITY CONTROL

- A. The membrane manufacturer's representative shall provide a comprehensive final inspection after completion of the roof system. All application errors shall be addressed and final punch list completed.

3.5 PROTECTION

- A. Protect installed roofing products from construction operations until completion of project.
- B. Where traffic is anticipated over completed roofing membrane, protect from damage using durable materials that are compatible with membrane.
- C. Repair or replace damaged products after work is completed.

END OF SECTION